

Silverpak 23C and 23CE
INTEGRATED STEP MOTOR,
DRIVER AND CONTROLLER(CE)
(23CE With optional encoder feedback – closed loop)

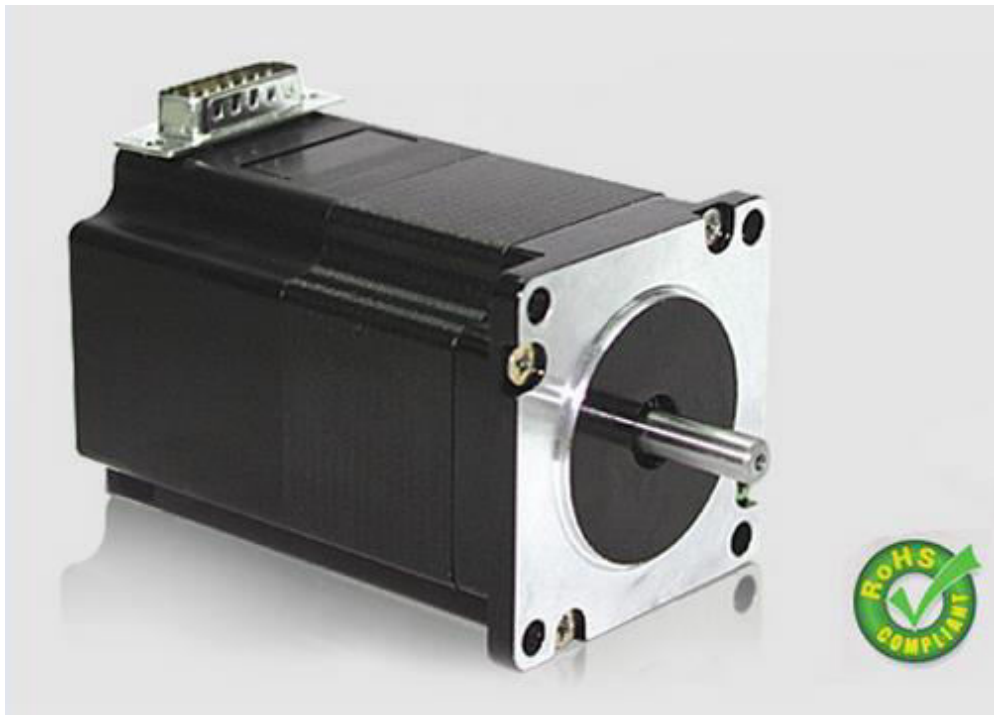

USER MANUAL

Rev 1.12

Thank you for purchasing the Silverpak 23C or 23CE integrated motor and controller with microstepping driver. This product is warranted to be free of manufacturing defects for one year from the date of purchase.

PLEASE READ BEFORE USING

Before you begin, ensure there is a suitable, +12V to +40V DC Power Supply. **Do not connect or disconnect the DB-15 cable while power is still being applied to the controller.** This will damage the board. Under any circumstances, do not exceed +40 VDC.

DISCLAIMER

The information provided in this document is believed to be reliable. However, no responsibility is assumed for any possible inaccuracies or omissions. Specifications are subject to change without notice.

Lin Engineering reserves the right to make changes without further notice to any products herein to improve reliability, function, or design. Lin Engineering does not assume any liability arising out of the application or use of any product or circuit described herein; neither does it convey any license under its patent rights, nor the rights of others.

Special Symbols



Indicates a WARNING and that this information could prevent injury, loss of property, or even death (in extreme cases).

Silverpak 23C/CE User Manual

Product: Silverpak 23C and 23CE
Version: 1.12
Date: 3/21/2018

Version History		
Version	Date	Description of Changes
1.00	01/10/2006	New User Manual
1.01	03/22/2006	Updated specs
1.02	04/06/2006	Updated specs: USB cable p/n.
1.03	02/27/2007	Standardization of all user manuals
1.04	12/14/2007	Updated designer kits, connection description, HyperTerminal connections
1.05	4/3/2009	Added RoHS RS485-232 card connection, updated opto sensor colors page 17.
1.06	9/14/2009	Updated mechanical dimensions
1.07	9/16/09	Updated LED image
1.08	9/18/09	Updated pinout description & Appendix for step/dir mode
1.09	10/29/2009	Added full stepping as a resolution option.
1.10	5/20/2015	Updated from Hyper Terminal to LinCommand
1.11	5/16/2016	Updated links and specs
1.12	3/21/2018	Update logo
1.13	1/27/2022	Update USB485 connection details

Table of Contents

1. FEATURES	5
Designer's Kit with USB communication	5
Designer's Kit with RS232 communication	5
Silverpak 23CE Encoder Option	6
Default Settings	6
2. ELECTRICAL SPECIFICATIONS	6
Digital I/O Specifications	6
Motor Specifications	6
3. OPERATING SPECIFICATIONS	7
Communication Specifications	7
4. MECHANICAL SPECIFICATIONS	7
Dimensions	7
5. PIN ASSIGNMENTS	8
Connecting to the USB card	9
Connecting to the RoHS RS232 card	9
6. CONNECTION SPECIFICATIONS	10
Quick Start for USB-485 converter card	10
Quick Start for RS232-485 converter card	11
Mating Connectors	11
7. CONFIGURING AND CONTROLLING THE SILVERPAK 23C	12
LinCommand Setup	12
Setting the Current	13
Connecting Multiple Silverpak 23C's	14
Setting/Changing the Address of the Controller	15
Connecting Accessories	15
8. TROUBLESHOOTING & FAQ	18
9. APPENDIX	19
Peak current versus Amps/Phase	200
Step and Direction Mode	21
Technical Support	21

1. FEATURES

- NEMA 23, 1.8° step motor integrated with controller/driver
- Operates from +12VDC to +40VDC
- Single 2 wire bus linking up to 16 SilverPak motors (RS485)
- 3.0 Amp Chopper (PWM) Driver
- Full step, 1/2, 1/4, 1/8, 1/16, 1/32, 1/64, 1/128, 1/256 step resolution
- Stand alone operation with no connection to a PC
- Execution Halt pending switch push button
- Pre-wired internally for connection to Opto Switch inputs
- Homes to an Opto or Switch closure with a single command
- Fully programmable ramps and speeds
- Four digital I/O and two fixed input channels
- Switch selectable address
- Software selectable "Move" and "Hold" currents
- Hold Current automatically selected upon move completion
- Simple DB15 connection
- Optional encoder feedback for position correction
- Opto inputs can be used as left & right limit switches

Designer's Kit with USB communication

Here is the list of components if you have purchased the optional Designer's Kit:

- USB to RS485 converter card
- A switch push button
- Opto Sensor
- A USB 6 foot long cable
- 3-Pin cable (optional usage)

Lin part number: USB Design Kit
SAP#: 4696327000049



Designer's Kit with RS232 communication

Here is the list of components if you have purchased the optional Designer's Kit:

- RS232 to RS485 converter card
- A switch push button
- Opto Sensor
- A 3-Pin cable (optional usage)

Lin part number: RS232KIT

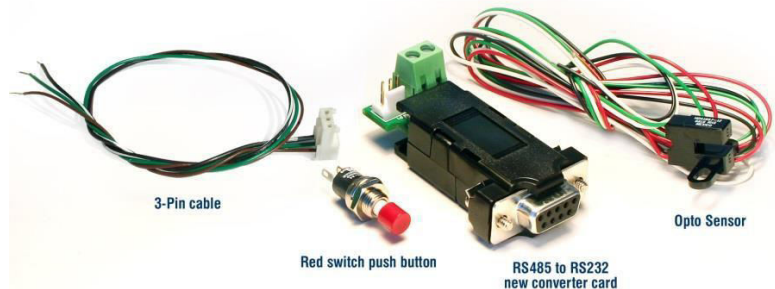

Silverpak 23CE Encoder Option

An E2, US Digital encoder is incorporated internally and is connected to the control board for a closed loop system. Position correction mode can be turned on such that it will continually send step pulses until the true desired position and actual position equals each other.

The encoder CPR is chosen by the user. Look in the commands guide regarding the encoder CPR if you do not know what your encoder CPR is.

Default Settings

Function (command)	Description
Running Current (m)	25% of 3.0 Amps
Holding Current (h)	10% of the run current
Step Resolution (j)	256x
Top Velocity (V)	305175 PPS (microsteps/sec)
Acceleration (L)	L=1000, 6103500 μ steps/sec ²
Position	0
Microstep smoothness (o)	1500
Outputs (J)	Both are turned off, J0, inputs 1 & 2
Baud Rate	9600 bps

Table 1: Default Settings

2. ELECTRICAL SPECIFICATIONS

Supply Voltage: +12 VDC to +40 VDC
 Peak Current: 0.3 to 3.0 Amps

Digital I/O Specifications

Number of I/O 4
 Number of Inputs 2
 Input Voltage +0 VDC to +5 VDC (0 to 24V tolerant, but 5V recommended)
 Input Current 700 mA
 Pull-up Resistors 20k Ω
 Protection Static Protection to the microprocessor

Motor Specifications

Any 5718 series step motor that is rated at 3.0 Amps/Phase or less can be combined into a Silverpak 23C or CE product. General torque specifications are listed below:

Holding Torque (max of 1.5 Amp Holding Current, winding specific)
 CO-5718S 50 to 100 oz-in
 CO-5718M 86 to 170 oz-in
 CO-5718L 140 to 294 oz-in

(In some circumstances, motors rated above 3 Amps, *may* be used, with a de-rated torque.)

Micro step size	1	2	4	8	16	32	64	128	256
Steps per Revolution	200	400	800	1600	3200	6400	12800	25600	51200

3. OPERATING SPECIFICATIONS

Maximum Step Frequency	2 ²⁴ (PPS) or 16.7MHz
Operating Temperature Range	0° to 50° C
Storage Temperature Range	-20° to 70° C

Communication Specifications

Interface Type	RS485 (USB or RS232 with a converter card)
Baud Rate	9600*, 19200, or 38400 bps
# Bits per character	8 Data
Parity	None
Stop Bit	1
Flow Control	None

*default

4. MECHANICAL SPECIFICATIONS

Dimensions

A. Max Overall Body Length

Motor body length is available in various lengths

Model 5718X (2.94")

Model 5718M (3.45")

Model 5718L (4.33")

B. Motor Front Shaft Extension Length

Standard length is 0.81". Customized shaft lengths are available.

C. Motor Shaft Diameter

Standard shaft diameter is 0.2500". Customized diameters are also available.

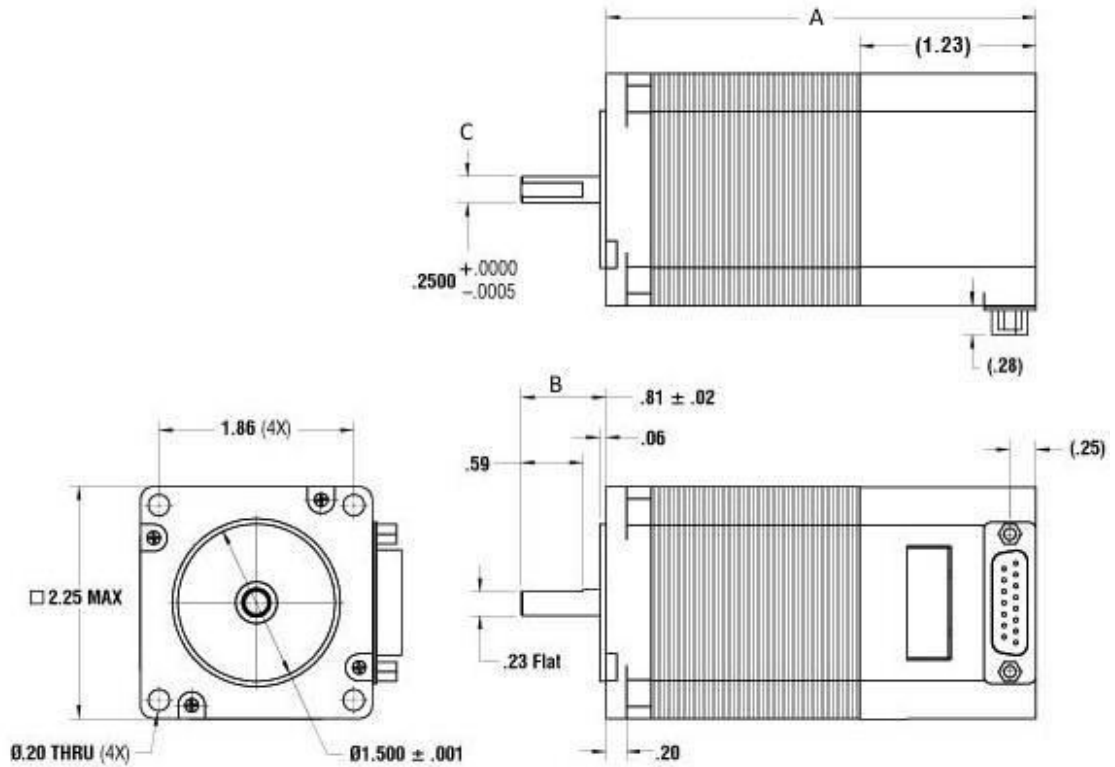

Figure 1: Dimensions

5. PIN ASSIGNMENTS

A DB-15 female connector cable receives power and provides the control connections for the Silverpak Unit. On the opposite end of the DB-15 female connector cable, there is a 3 pin connector provided for the converter card in order for the driver to communicate with the PC. This allows the user to solder and program the switch push button and the Opto Sensor, enabling several options. The four I/O wires are colored Orange, Orange/White, White and Red/White. This will allow for options such as solenoids, relays, opto isolators, LED's and many other input and output connections.

PIN #	COLOR	FUNCTION	I/O # or Function
1	Green	Power Ground	
2	Black	1A On/Off Output	Driver 2
3	White / Green	Direction Input (see Appendix D)	
4	Yellow	+5VDC Input for Opto Isolated STEP and DIR (see Appendix D)	
5	Orange	Input 2	2/Jog2 Input
6	Yellow White	Internal Power for Opto Sensor	
7	Orange / White	Input 3 (Opto Input)	3/Opto1 Input
8	Black White	RS485 A	
9	Red	+12V TO +40V POWER	
10	Blue	1A ON/OFF Output	Driver 1
11	Blue White	Step Input (see Appendix D)	
12	Green White	Signal Ground	
13	White	Input 1	1/Jog1 Input
14	Red White	Input 4	4/Opto2 Input
15	Brown	RS485 B	

*Inputs are labeled 1, 2, 3 and 4 for programming the 'Halt' and 'Skip' Commands.

Table 2: Pin assignments

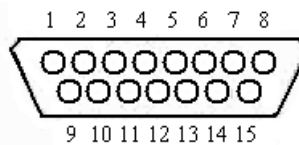
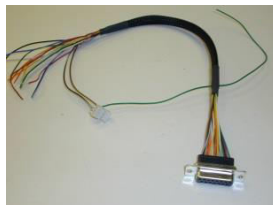

Figure 2: DB-15 Female Cable Connector (Rear View)



Lin Part #: 090-00096

Connecting to the USB card

SP23C pin#	SP23C color	*USB pin#
8	Black/white	3 (D+/A+, RS485A)
1	Green	1 (GND connect to Power Supply Ground)
15	Brown	2 (D-/B-, RS485B)

Table 3: Pinouts for using USB

*Pin #1 is located here:



Figure 3: USB to RS485 converter card, p/n USB485

The USB converter card does not require power (it receives power from the PC). Power is still needed for the R256 controller/driver. Pin 8 and 15 from the DB-15 Wire harness may have a connector on it, to use with our updated USB485 converter card, simply cut the connector and directly mate Pin 8 and 15 to the USB485 converter card per the pinout above. Note: On the connector there is a loose green wire, please use this to connect GND on the USB485 to Power Supply GND, Pin 1, on the Silverpak 23 Unit.

Connecting to the RoHS RS232 card

SP23C pin#	SP23C color	RS232 card pin#
8	Black/white	1 (RS485A)
1	Green	2 (GND connect to Power Supply Ground)
15	Brown	3 (RS485B)

Table 4: Pinouts for using RS232

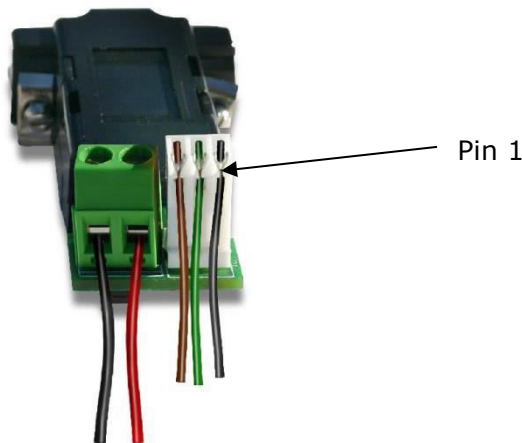

Figure 43: RS232 to RS485 converter card, p/n 083-00050
The RS232 card requires power (7-40VDC).

6. CONNECTION SPECIFICATIONS



DO NOT PLUG IN POWER UNTIL AFTER EVERYTHING IS CONNECTED.

Quick Start for USB-485 converter card

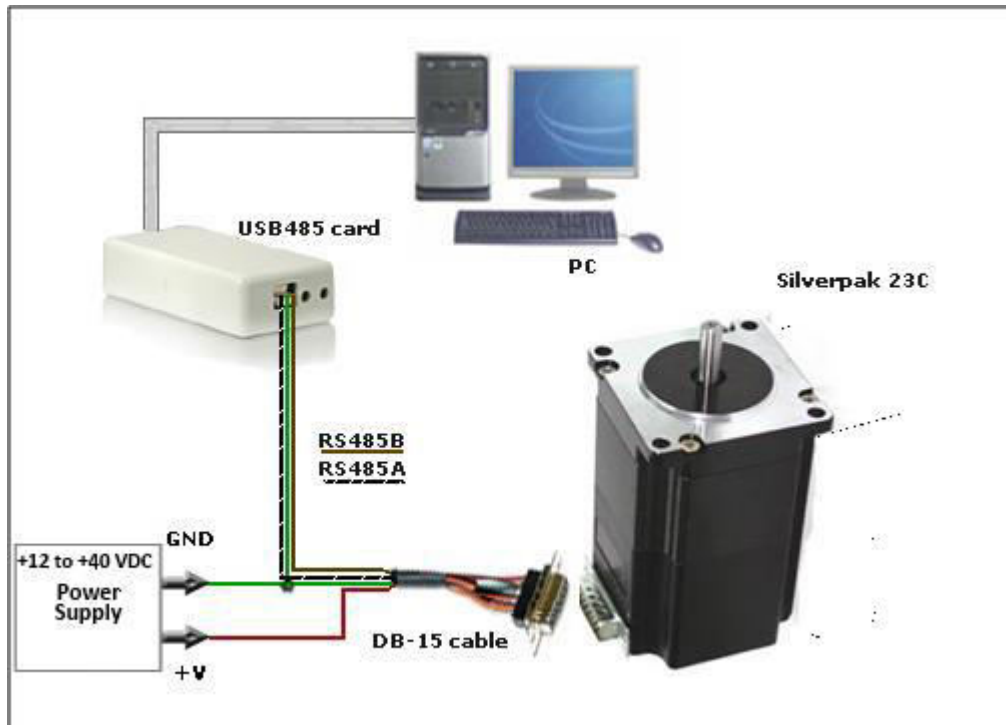

Figure 6: Connection using USB

1. The USB converter card connects to the Silverpak using the DB-15 cable that is provided to you. The 3-Pin connector is placed onto the USB485 converter card. If using our updated USB485, you can remove the connector and directly mate pin 8 and 15 to the USB485 card. Note: When removing the connector, there is a stray green wire, please use this wire to connect the GND on the USB485 to power supply GND, pin 1, on the Silverpak 23 Unit.
2. Your power supply will be connected to the Silverpak directly. The USB card is powered via the PC. **SilverPak's pin 9, Red wire is +12 to +40 VDC. Pin 1, green wire is ground.**
3. Connect the USB485 card to your PC using the USB cable provided to you.
4. Turn your power supply on and follow instructions for using LinCommand.

Quick Start for RS232-485 converter card

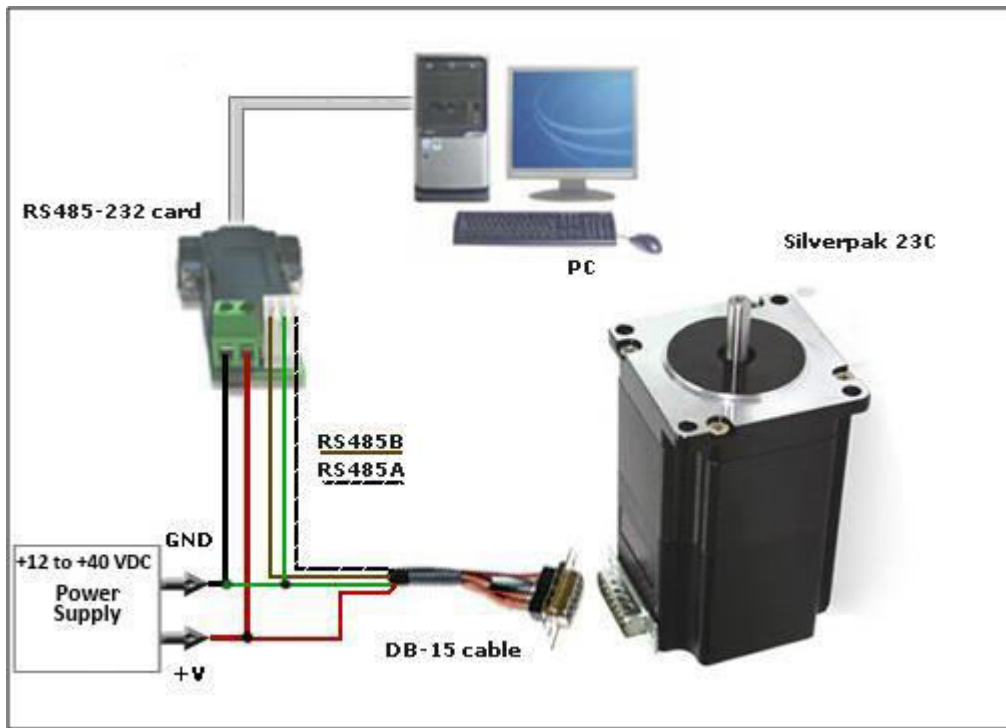
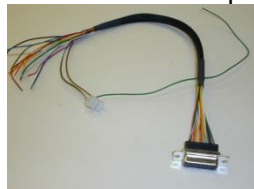

Figure 5: Connection using RS232

1. The RS232 converter card connects to the Silverpak using the DB-15 cable that is provided to you. The 3-Pin connector is placed onto the converter card.
2. Your power supply will be connected to the RS232 card where the green header is located. **'+' is for +12VDC to +40VDC. '-' is for the Power Supply Ground.**
3. **The Silverpak requires power.** Pin 9 (red) is for power, Pin 1 (green) is for ground.
4. Connect the RS232 card to your PC with a female to female DB-9 cable.
5. Turn your power supply on and follow instructions for using LinCommand.

Mating Connectors

A mating DB-15 cable is provided with each Silverpak 23C.



Part # 090-00096 is the DB-15 cable that has a 3-Pin header for the USB card or RS485 card

7. CONFIGURING AND CONTROLLING THE SILVERPAK 23C

LinCommand Setup

For more detailed instructions, please refer to the LinCommand Manual.

[LinCommand Manual](#)

Follow these steps to set up and use LinCommand:

Note: If LinCommand has not been installed on your computer, you may download the program in 32 Bit or, 64 Bit, from the link below. After downloading, navigate to the 'Setup' file and double click 'Setup' to install.

[LinCommand 32 Bit](#)

[LinCommand 64 Bit](#)

1. After installation, double click on the LinCommand icon , to launch the LinCommand program.
2. Choose, "R356/Silverpak 23" from the drop down box and then click [OK].
3. LinCommand opens in 'Normal' mode with a GUI interface for controlling the stepper motor. For Advance mode skip to step 8 below.
4. To continue in the 'Normal' mode, choose your COM port, baud rate, and controller address (See page 13 Figure 9) and then click [Connect],
5. Choose the 'Motor Settings' tab. Set the Run Current*, Hold Current, Step Resolution, Velocity, and Acceleration then click [Add Settings to Queue].



CAUTION Do Not Exceed Motors Peak Current or, Damage to the Motor and Controller Could Result! See "Setting the Current" on following page.

6. Double click on the "Click Here to Add Command" to bring up the motor control menu.
7. For more instructions, please refer to the LinCommand Manual.
8. To operate in the 'Advanced mode', Choose 'Options' and select 'Advanced mode'.
9. Select your COM port and baud rated and then click [Connect].
10. Enter command strings on one of the 7 lines in the 'Send' window and click 'Send' to send the command line to the controller.
11. For a complete list of commands and their definitions refer to the, Silverpak23C-R356 commands manual.

Example command: /1A1000R

- This will run unit #1 to the Absolute position 10000
- You can check the address of your driver by checking the dial at the top of the driver. (See the following page for Changing the Address)
- A full list of commands is available in the Silverpak 23C / R356 Command List
- Hint: Most common commands to change are:
 - Step resolution (/1j2R sets it to half stepping)
 - Velocity in pulses/sec (/1V1000R sets the speed to 1000 pps)
 - Run current (/1m50R sets the run current to 50%)
 - Hold current (/1h20R sets the hold current to 20%)
 - Move the motor (/1P800R moves the motor 2 revs if half stepping)

Responses:

- /0@ indicates good command and that it was received correctly
- /0b indicates bad command
- /0C indicates that the command is out of range
- /0' indicates that the command is terminated
- /0'a Overflow

Setting the Current



CAUTION! DO NOT SET THE CURRENT ABOVE THE MOTOR'S RATED CURRENT.

In order to set the correct current for your motor, you must program the specified amount in LinCommand.

Current is set based on the Maximum amount of current the controller board can output, which is 3.0 Amps Peak. Below is a table of how much current will be applied to your motor for each setting.

Percent	Command		Motor's Current Rating (Amps/Phase)	Driver's Equivalent Current (Amps Peak)
10%	m10	=	0.21	0.30
20%	m20	=	0.43	0.60
30%	m30	=	0.64	0.90
40%	m40	=	0.86	1.20
50%	m50	=	1.07	1.50
60%	m60	=	1.29	1.80
70%	m70	=	1.50	2.10
80%	m80	=	1.71	2.40
90%	m90	=	1.93	2.70
100%	m100	=	2.14	3.00

Table 5: Desired Current

To achieve the equivalent Driver Current (Amps), multiply your motor's rated current by 1.4. Follow these examples:

Example One:

You have a motor that is rated at **0.85** Amps, $0.85 \text{ Amps} \times 1.4 = \sim 1.2 \text{ Amps}$. Using *Table 5* we would see that 1.2 Amps is 40% of the driver's maximum output current.

Assuming the Silverpak is addressed to Number 1, this is what you'd program:

/1m40R

Example Two:

You have a motor that is rated at **1.0** Amps, and your Controller is addressed to Number 1, this is what you'd program: **/1m46R**

This will set the controller to 1.4 Amps Peak. How did we get 1.4 Amps? $\rightarrow 1.0 \text{ Amps} \times 1.4 = 1.4 \text{ A Peak}$. (See page 21, "Peak Current vs Amps/Phase" for more details.)

WARNING!: Setting the Current to a value greater than the Motor's rated current will damage your motor, and may overheat the controller.

Connecting Multiple Silverpak 23C's

When using the USB485 converter card, connect all power and ground lines on the SilverPak units to the main power supply. Then daisy chain the RS485+ and RS485- lines prior to plugging into the USB485 card. **Do not apply power until after all connections have been completed.**

Be sure to also ground the **USB485** card Pin 2, to power supply ground.

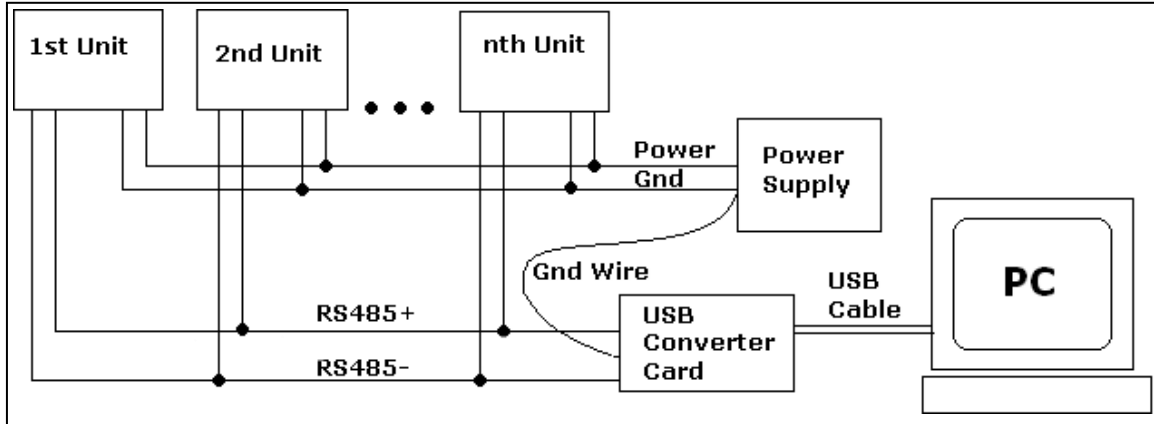

Figure 7: Connection using USB485Converter Card

When using the **RS232-to-RS485** converter card, daisy chain all four wires: power, ground, RS485+ and RS485- prior to plugging into the converter card.

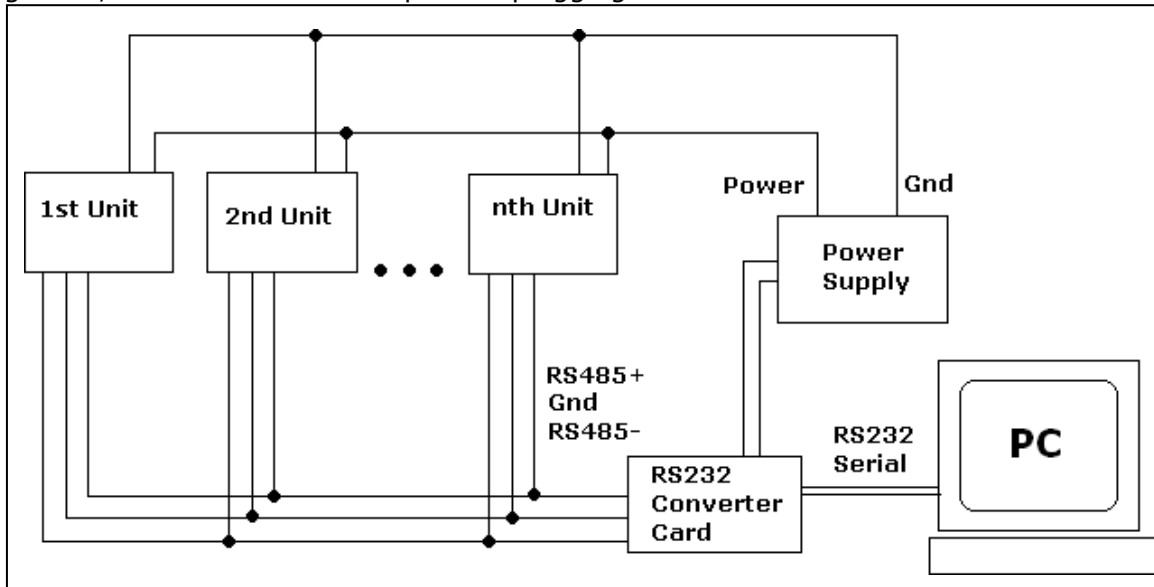

Figure 8: Connection using RS232 Converter Card

Setting/Changing the Address of the Controller

Use a small screwdriver to turn the dial on the bottom of the SilverPak motor, so that the arrow points to the desired Address. Use this number when programming commands. For example, /1P1000R



Figure 9: Address Dial

Connecting Accessories

If you have purchased the Designer's Kit, there is a Red Push Button and an Optical Sensor included. Follow the schematics below in order to properly assemble accessory pieces.

Push Button

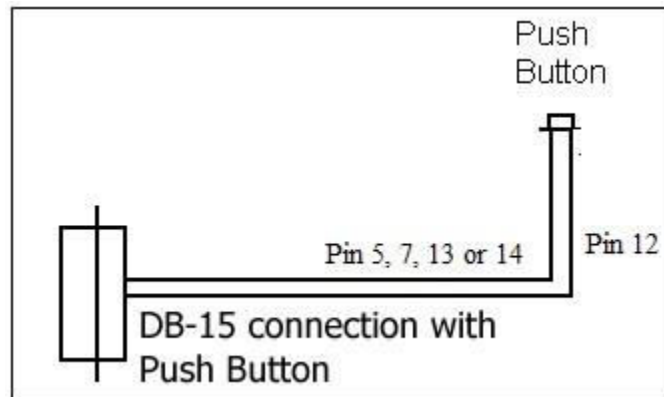

Figure 10: Push Button Schematic

Pins 5, 7, 13 and 14 can all be used with push buttons. Below shows the corresponding input numbers for these pins.

Input 1	Pin 13	White
Input 2	Pin 5	Orange
Input 3	Pin 7	Orange/White
Input 4	Pin 14	Red/White

Table 6

LED or other output

The two I/O lines, pins 2 & 10, can drive an external device such as solenoids, LED's, or switches. The bidirectional I/O's are switches to ground internally, and therefore need to be connected to the +V of the power supply. Below is a recommended connection for lighting an LED with 20m Amps:

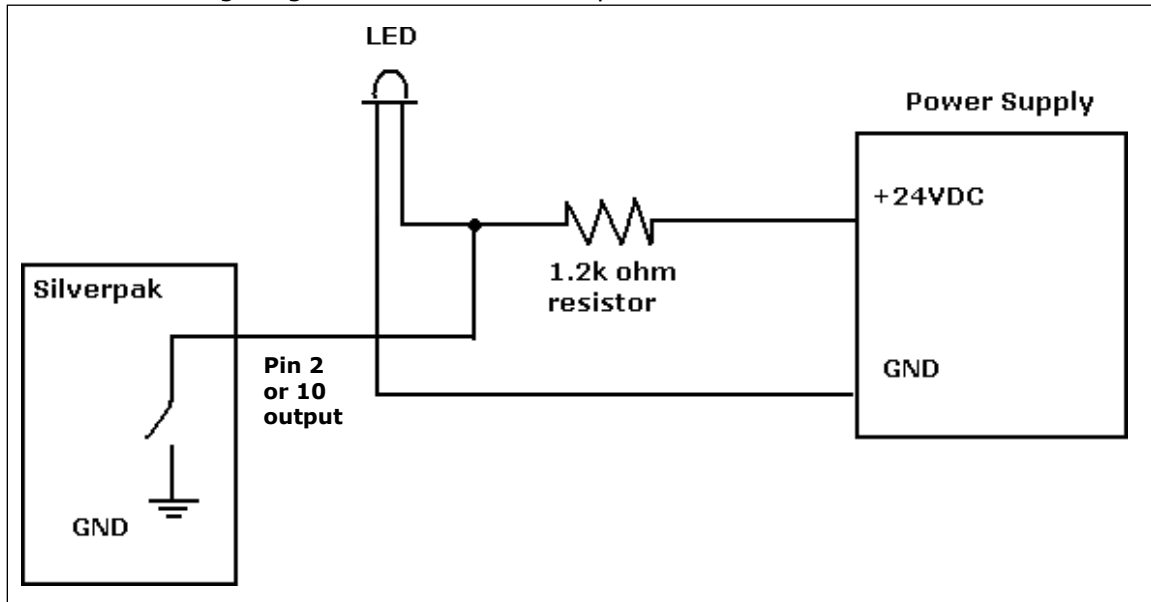

Upon entering command /1J0R, both pins 2 & 10 will output 1 Amps. The 1.2k ohm resistor will limit the current to 20mAmps into the LED. Select any ohm value to limit your current based on the device that is connected to the output. I/O's are 24VDC tolerant.

Optical Sensor

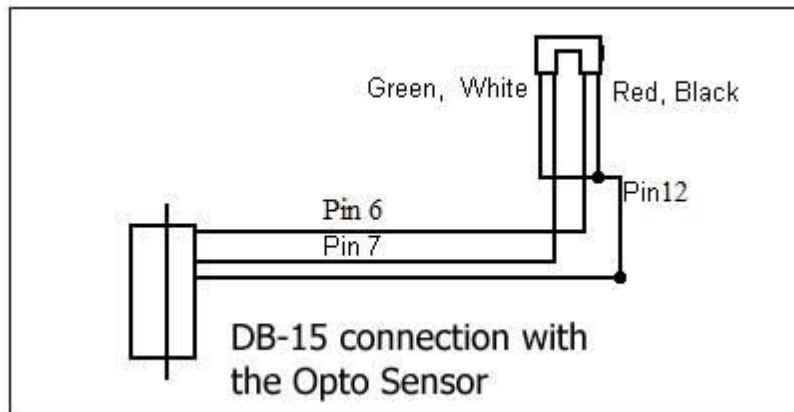

Figure 11: Opto Sensor Connection Schematic

The Opto Sensor uses Pins 6, 7, and 12. Use the following table to solder the

Optical Sensor	DB15 Cable	Pin #
Green →	Green white	12
Black →	Green/white	12
Red →	Yellow /white	6
White →	Orange/white	7

Table 7

Encoder Usage

The Silverpak 23CE **can do closed loop position correction**. The encoder connects to the board internally.

Position Correction Mode

Position correction mode, when enabled will issue steps to the motor until the encoder reads the correct position. Once enabled, positions are given in Quadrature encoder counts of the encoder – **not in microsteps**. If the motor stalls during a move then this mode will reattempt the move until the encoder reads the correct number, or until it has tried a certain number of times and times out (the au command).

First: Set the Encoder Ratio:

Encoder ratio = [(Microstep * 200 steps/rev) / (CPR *4)]*1000

This must be a whole number after you multiply by 1000.

For example: a 1.8° motor set to 256x microstepping with a 1000 count encoder:

Encoder ratio = ((200 * 256)/(1000*4))*1000 = 12800

Set encoder ratio: /1aE12800R

If Encoder Ratio is Unknown:

Follow these steps:

1. Issue a /1n0R to clear any special modes
2. Issue a /1z0R to set position of encoder and controller to zero
3. Issue a /1A100000R and ensure the move completes at a velocity that does not stall.
4. Issue a /1?0 to read current position. This should be 100000.
5. Issue a /1?8 to read the encoder position
6. Issue a /1aE0R which auto divides these two numbers
7. Issue a /1?aE which read backs the encoder ratio computed
8. This value is a rough guide and may be a few counts off due to inaccuracies in the motor position and run-out of the encoder, but use the EXACT number that was returned and set it with a /1aEXXXR. Or, please contact Lin Engineering and provide us with your motor part number and we can look up the encoder CPR for you.

Second: Set the Error in Quadrature Encoder Ticks allowed before correction begins:

/1aC50R (default is 50) Motor will move 50 encoder ticks away from desired position before position correction takes place. If aC is set to too small of a value, the motor may oscillate back and forth trying to locate the exact position. Use a larger aC value.

Third: Set the Overload Timeout Value:

This is the number of re-tries allowed under a stall condition: /1au10000R (default is 10)

Fourth: Enable the Feedback mode:

Zero the positions prior to enabling the feedback mode: /1z0R

Issue /1n8R to enable the feedback mode.

Overload Report Mode

Overload report mode when enabled, will compare the encoder value to the commanded position at the end of a move and report an error if the two values do not match within the range given by "aC". When this error occurs the drive will exit from any loops or strings it may be executing.

Overload report mode is enabled by /1n16R, and requires the encoder ratio to be

entered correctly via the "aE" command. Issue a /1zR to zero both the encoder and position counter just prior to issuing /1n16R. Only the Position Correction mode or the Overload Report mode may be turned on at one time.

Notes:

1. When any command is received by the drive it will always respond with its status. The drive will only accept a command when it is not busy. This status byte received must be checked to ensure that the unit was not busy and that the command was accepted. This is especially important when position correction mode is enabled, because the drive may be attempting to correct position all by itself, and will reject an externally (via RS232) received command if it is busy in the middle of a correction move.
2. When position correction mode is enabled, /1n8R, then the drive will keep retrying any stalled moves, and will NOT halt any strings or loops upon detection of a stall.
3. During position correction mode /1T will halt any move, but there is a possibility that the drive may instantly reissue itself a position correction command, especially if it is fighting a constant disturbance. It may be necessary to issue a /1n0R to positively halt a move in progress.
4. Position correction mode is inhibited if the encoder underflows and goes negative (but will automatically resume if a move is made into the positive range). If position correction is required at the zero point, please redefine zero to be a slightly positive number with the "z" command. Eg /1z10000R
5. If the encoder ratio is changed from its default of 1000, the allowed max position will be decreased from $+2^{31}$ by the same ratio.

8. Troubleshooting & FAQ

Communication problem between computer and controller:

Is the correct COM Port selected? Use an operating system of Windows 98 or higher. Are you working on a Laptop? Sometimes there is a shift in Ground on Laptop Serial Ports. Pin 5 on the Serial Port is Ground. Make sure that this is connected to a true ground.

Is the LED flashing on the R256 Controller? A flashing light indicates it is waiting for Commands and power is OK. Motor shaft should be difficult to rotate.

RS232-RS485 communication problem:

Check the RS232 to RS485 Converter Card. Use a voltmeter to verify Power is coming into the card correctly and if power is being supplied to the Controller properly.

Can communicate with LinCommand, but no motor movement:

Check that power is being supplied to the system. Motor shaft should be holding in one place and the RS232 type of converter card should be receiving power and sending power via the + and - of the Red 4 Pin connector. Use a voltmeter to verify.

Is the Silverpak23C set to the correct Address? Check the Dial on the bottom of the unit. The white arrow should be pointing to the corresponding Address. Make sure that the arrow is not between two addresses. Use a small screw to verify that it clicks in place.

Note the description of the following response strings
/0' indicates that the command is terminated

/0@ indicates good command and that it was received correctly
/0C indicates that the command is out of range
/0b indicates bad command

The unit is by default, set to 256 microsteps. Therefore, by typing in a position move of /1P200R, you will not see anything. It takes 51,200 steps to make one revolution, so try a large value, like /1P100000R

Silverpak 23C will accept command, but Motor stalls in middle of command:

This means there is not enough current being supplied to the Motor. Use the m command to change the current, or run the Motor at a Lower Speed (V command). Or, make the motor accelerate slower using the L command.

I want to use one of the I/Os to turn on a LED to confirm that the motor has finished moving or moved to a certain position. How do I do it?

To turn on a LED to confirm that the motor finished moving you must use the "J" command in the command list section On/Off Drivers. We are assuming the unit executes the command sent. We cannot detect skipping because the setup is open loop. Example: /1P200J10R, is a position move 200 steps, then turn on driver 2.

What's the minimum and maximum voltage the RS485 to RS 232 Converter Card can handle? Min and Max voltage levels: 7 to 40 VDC (SilverPak 23 requires +12 to + 40VDC)

Using a PLC to communicate with board

After the command, you need to issue a carriage return and linefeed.

Example: /1A1000R (absolute position move 1000). After the R, send a 0x0d in hex.

**USB485 interface card driver not communicating
Reinstall USB485 driver**

1. Go to Windows Device Manager
2. Under the Ports Section, the USB485 should show as the
"Prolific PL2303GL USB Serial COM Port (COM XX)"
3. If it does not show as this, it might show as the "USB Serial Controller".
4. If so, right click on this and "Update the driver". The name should change to the above as intended.
5. If it does not, please go this [link](#) to download and install the driver from the original Chip manufacturer.
6. Select the **PL23XX-M_LogoDriver_Setup.exe** and install. The name should now populate to **"Prolific PL2303GL USB Serial COM Port (COM XX)"**
7. When you send a command via Lin Command, a Yellow and Green light will blink to show that the command has been sent successfully.

9. Appendix

Peak current versus Amps/Phase

Where does the 1.4 times come from? Current is continuously changing when a motor steps. If the motor is rated for 1.0 A/Phase, it may receive 0 Amps, 1 Amp, 1.4 Amps, or anything in between if you are microstepping. For ease of explanation, we will look at the current waveform when we half step, or set the driver/controller to 2x microstepping.

If we take a look at both the A and B phases, and plot on an X-Y chart of when each phase receives current, and how much it receives, it will look like the chart below. Beginning at position 1, Phase A receives negative current, and Phase B receives positive current. Let's assume it is at coordinate (-1, 1).

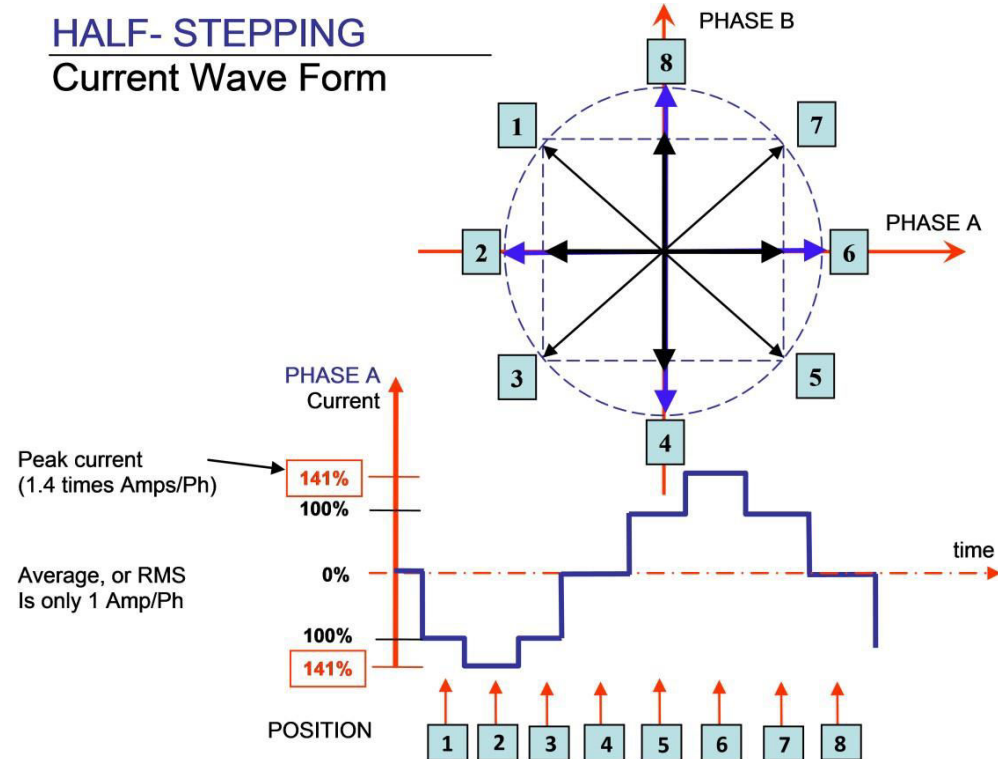

The position versus time graph just above, plots only the A Phase, following the eight different steps the motor will make. Current is changing with each position. Recall that a negative in electronics simply means reverse direction of current flow.

<p>1.41 AMP ($\sqrt{2}$)</p> <p>1 AMP</p> <p>1 AMP</p>	<p>Take a look at position #7. If we were to draw the arrow at position 7 as the hypotenuse of a triangle, it would look like the triangle to our left. Recall from geometry a 90°-45°-45° triangle is a 1-1-$\sqrt{2}$ combination. The $\sqrt{2}$, or 1.4 value is also the radius of the dotted circle shown above. Therefore, during certain steps, Phases A or B will receive 1.4 Amps of current. But the average, or RMS current throughout these 8 steps is only 1.0 Amps. RMS and Amps/Phase is the same meaning.</p>
---	--

The 1.4A along this hypotenuse is also known as the 2-Phase On position, since both A and B Phases are "On" and receive current. It is also known as the **peak current**.

As we see the waveform that's plotted for the A Phase, the highest value on the curve is known as the peak value.

Motors have a rated current, or average RMS value since in operation, the current is continuously changing. The most logical way to describe a rating is to take an average, or RMS (root means squared) value. But drivers understand current in terms of peak current, therefore the conversion is: **Amps/Phase x 1.4 = Amps Peak**

Step and Direction Mode

The Silverpak 23C or 23CE units can be configured as a driver only by first connecting it to your PC and saving the special mode "n96" in program memory storage zero.

1. First connect to your PC and save n96 in storage zero:
/1s0n96R
2. Next, connect the positive side of a TTL squarewave for step pulses to Pin 11 (Blue/white wire).
3. Connect a +5VDC supply to Pin 4 (Yellow wire).
4. Tie together the negative pin of the step pulse to the negative 5VDC supply. This becomes your signal ground.
5. Change direction of rotation on the fly by connecting or disconnecting Pin 3 (White/green wire) to the signal ground that was just created in Step 4.

The unit can still accept commands via RS485 when in step & direction mode but move commands via RS485 will override step pulses.

Technical Support

(Mon.-Fri., 8:00 a.m.-5:00 p.m.)

Our technical support group is glad to work with you in answering your questions. If you cannot find the solution to your particular application, or, if for any reason you need additional technical assistance, please contact our technical support by phone at, **408-919-0200**, email at, techsupport@linengineering.com, on the Web: www.linengineering.com , or, Our online Live Support

